

# *The Basics of* Electrochemical Impedance Spectroscopy



CORROSION



BATTERY TESTING



COATINGS



PHOTOVOLTAICS



C3 PROZESS- UND  
ANALYSENTECHNIK GmbH  
Peter-Henlein-Str. 20  
D-85540 Haar b. München  
Telefon 089/45 60 06 70  
Telefax 089/45 60 06 80  
Info@c3-analysentechnik.de  
www.c3-analysentechnik.de

gamry.com





## Contents

---

<i>What is Electrochemical Impedance Spectroscopy (EIS)?</i> .....	3
<i>Data Presentation</i> .....	8
<i>Linearity of Electrochemistry Systems</i> .....	10
<i>Additional Resources</i> .....	17

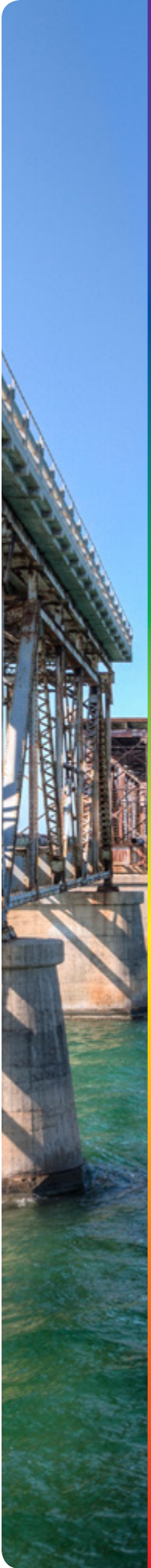

# What is Electrochemical Impedance Spectroscopy (EIS)?

---

Simply put, EIS is a powerful tool that can simulate real-world electrochemical behaviors using multiple parameters that can be automated, providing a system of measurement and validation.

In this four-part series of articles, we will review the basics of EIS and how you can apply this technique to the study and testing of batteries, fuel cells, coatings, and corrosive reactions.

## Part I – AC Circuit Theory and Representation of Complex Impedance Values

### *Impedance Definition: Concept of Complex Impedance*

Almost everyone knows about the concept of electrical resistance. It is the ability of a circuit element to resist the flow of electrical current. Ohm's law (Equation 1) defines resistance in terms of the ratio between voltage,  $E$ , and current,  $I$ .

1  $R \equiv \frac{E}{I}$

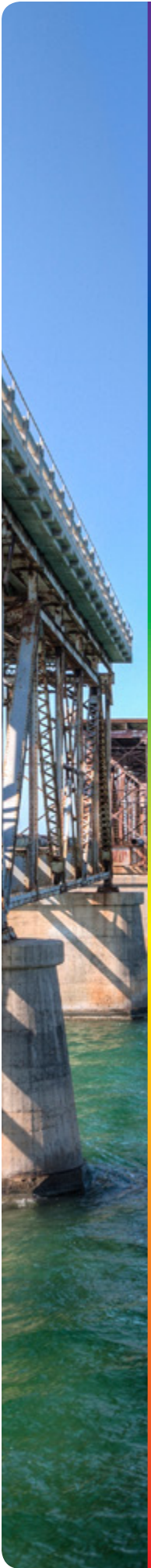

***While this is a well-known relationship, its use is limited to only one circuit element - the ideal resistor. An ideal resistor has several simplifying properties:***

- It follows Ohm's Law at all current and voltage levels.
- Its resistance value is independent of frequency.
- AC current and voltage signals through a resistor are in phase with each other.

However, the real world contains circuit elements that exhibit much more complex behavior. These elements force us to abandon the simple concept of resistance, and in its place we use impedance, a more general circuit parameter. Like resistance, impedance is a measure of the ability of a circuit to resist the flow of electrical current, but unlike resistance, it is not limited by the simplifying properties listed above.

Electrochemical impedance is usually measured by applying an AC potential to an electrochemical cell and then measuring the current through the cell. Assume that we apply a sinusoidal potential excitation. The response to this potential is an AC current signal. This current signal can be analyzed as a sum of sinusoidal functions (a Fourier series).



Electrochemical impedance is commonly measured using a small excitation signal. This is done so that the cell's response is pseudo-linear. In a linear (or pseudo-linear) system, the current response to a sinusoidal potential will be a sinusoid at the same frequency but shifted in phase (see Figure 1). Linearity is described in more detail in the following section.

Figure 1. Sinusoidal Current Response in a Linear System

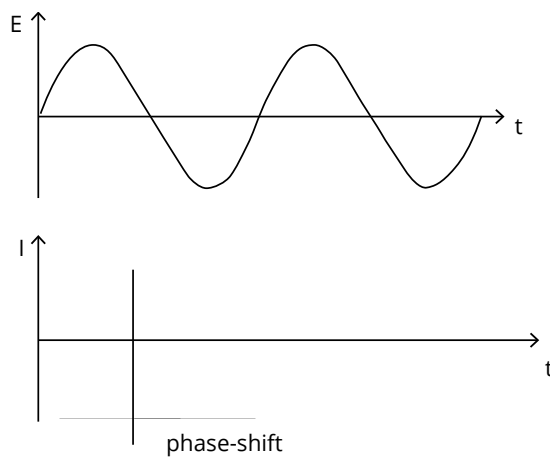

The excitation signal, expressed as a function of time, has the form

2  $E_t = E_0 \sin(\omega t)$

where  $E_t$  is the potential at time  $t$ ,  $E_0$  is the amplitude of the signal, and  $\omega$  is the radial frequency. The relationship between radial frequency  $\omega$  (expressed in radians/second) and frequency  $f$  (expressed in hertz) is:

3  $\omega = 2\pi f$

In a linear system, the response signal,  $I_t$ , is shifted in phase ( $\phi$ ) and has a different amplitude than  $I_0$ .

4  $I_t = I_0 \sin(\omega t + \phi)$

An expression analogous to Ohm's Law allows us to calculate the impedance of the system as:

$$5 \quad Z = \frac{E_t}{I_t} = \frac{E_0 \sin(\omega t)}{I_0 \sin(\omega t + \phi)} = Z_0 \frac{\sin(\omega t)}{\sin(\omega t + \phi)}$$

The impedance is therefore expressed in terms of a magnitude,  $Z_0$ , and a phase shift,  $\Phi$ .

If we plot the applied sinusoidal signal  $E(t)$  on the X-axis of a graph and the sinusoidal response signal  $I(t)$  on the Y-axis, the result is an oval (see Figure 2). This oval is known as a "Lissajous Figure". Analysis of Lissajous Figures on oscilloscope screens was the accepted method of impedance measurement before the availability of modern EIS instrumentation.

Figure 2. Origin of Lissajous Figure

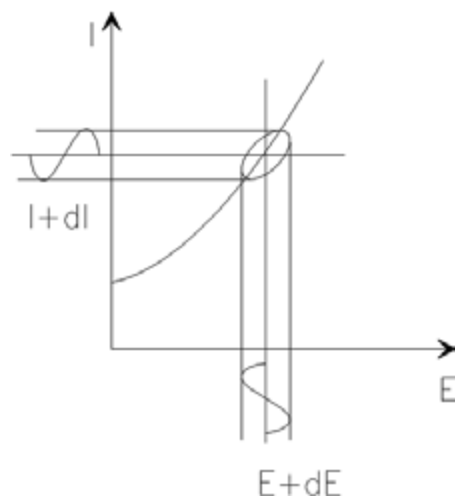



With Euler's relationship,

6  $\exp(j\phi) = \cos\phi + j\sin\phi$

it is possible to express the impedance as a complex function. The potential is described as,

7  $E_t = E_0 \exp(j\omega t)$

and the current response as,

8  $I_t = I_0 \exp(j\omega t - \phi)$

The impedance is then represented as a complex number,

9  $Z(\omega) = \frac{E}{I} = Z_0 \exp(j\phi) = Z_0 (\cos\phi + j\sin\phi)$

## Data Presentation

Look at Equation 9 in the previous section. The expression for  $Z(\omega)$  is composed of a real and an imaginary part. If the real part is plotted on the X-axis and the imaginary part is plotted on the Y-axis of a chart, we get a “Nyquist Plot” (see Figure 3). Notice that in this plot the Y-axis is negative and that each point on the Nyquist Plot is the impedance at one frequency. Figure 3 has been annotated to show that low frequency data are on the right side of the plot and higher frequencies are on the left.

On the Nyquist Plot the impedance can be represented as a vector (arrow) of length  $|Z|$ . The angle between this vector and the X-axis, commonly called the “phase angle”, is  $\phi (= \arg Z)$ .

Figure 3. Nyquist Plot with Impedance Vector

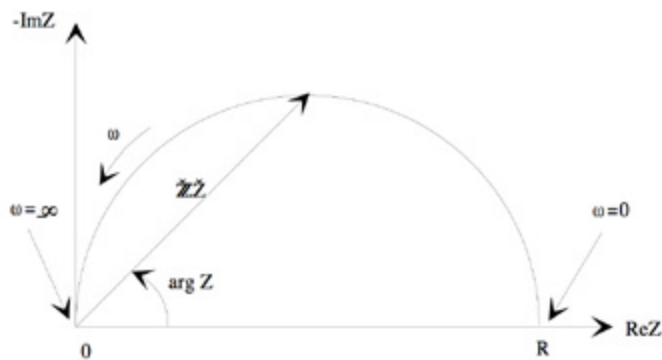

Nyquist Plots have one major shortcoming. When you look at any data point on the plot, you cannot tell what frequency was used to record that point.



The Nyquist Plot in Figure 3 results from the electrical circuit of Figure 4. The semicircle is characteristic of a single "time constant". Electrochemical impedance plots often contain several semicircles. Often only a portion of a semicircle is seen.

**Figure 4. Simple Equivalent Circuit with One Time Constant**

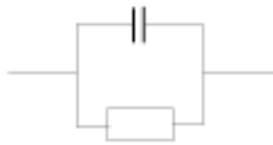

Another popular presentation method is the Bode Plot. The impedance is plotted with log frequency on the X-axis and both the absolute values of the impedance ( $|Z|=Z_0$ ) and the phase-shift on the Y-axis.

The Bode Plot for the electric circuit of Figure 4 is shown in Figure 5. Unlike the Nyquist Plot, the Bode Plot does show frequency information.

**Figure 5. Bode Plot with One Time Constant**

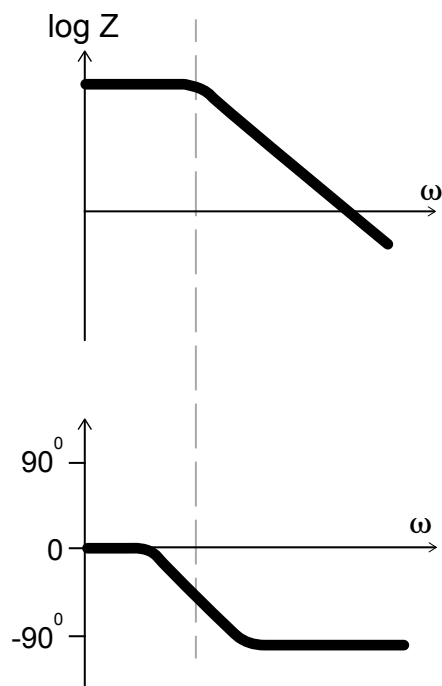



## Linearity of Electrochemistry Systems

---

Electrical circuit theory distinguishes between linear and non-linear systems (circuits). Impedance analysis of linear circuits is much easier than analysis of non-linear ones.

***The following definition of a linear system is taken from Signals and Systems by Oppenheim and Willsky:***

A linear system ... is one that possesses the important property of superposition: If the input consists of the weighted sum of several signals, then the output is simply the superposition, that is, the weighted sum, of the responses of the system to each of the signals. Mathematically, let  $y_1(t)$  be the response of a continuous time system to  $x_1(t)$  and let  $y_2(t)$  be the output corresponding to the input  $x_2(t)$ . Then the system is linear if:

- 1) The response to  $x_1(t) + x_2(t)$  is  $y_1(t) + y_2(t)$
- 2) The response to  $ax_1(t)$  is  $ay_1(t)$  ...

For a potentiostated electrochemical cell, the input is the potential and the output is the current. Electrochemical cells are not linear! Doubling the voltage will not necessarily double the current.

However, Figure 6 shows how electrochemical systems can be pseudo-linear. If you look at a small enough portion of a cell's current versus voltage curve, it appears to be linear.

**Figure 6. Current versus Voltage Curve Showing Pseudo-Linearity**

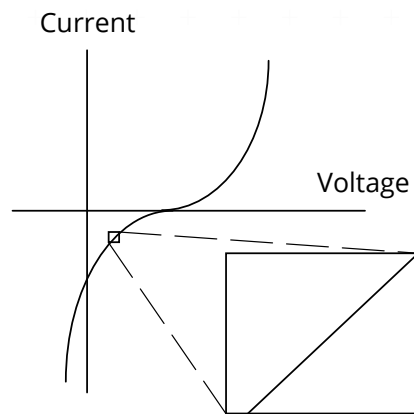

In normal EIS practice, a small (1 to 10 mV) AC signal is applied to the cell. With such a small potential signal, the system is pseudo-linear. We don't see the cell's large nonlinear response to the DC potential because we only measure the cell current at the excitation frequency.

If the system is non-linear, the current response will contain harmonics of the excitation frequency. A harmonic is a frequency equal to an integer multiplied by the fundamental frequency. For example, the "second harmonic" is a frequency equal to two times the fundamental frequency.

Some researchers have made use of this phenomenon. Linear systems should not generate harmonics, so the presence or absence of significant harmonic response allows one to determine the systems linearity. Other researchers have intentionally used larger amplitude excitation potentials. They use the harmonic response to estimate the curvature in the cell's current voltage curve.

## ***Steady State Systems***

Measuring an EIS spectrum takes time (often up to many hours). The system being measured must be at a steady state throughout the time required to measure the EIS spectrum. A common cause of problems in EIS measurements and analysis is drift in the system being measured.

In practice, a steady state can be difficult to achieve. The cell can change through adsorption of solution impurities, growth of an oxide layer, build-up of reaction products in solution, coating degradation, or temperature changes, to list just a few factors.

Standard EIS analysis tools may give you wildly inaccurate results on a system that is not at steady state.

## ***Time and Frequency Domains and Transforms***

Signal processing theory refers to data representation domains. The same data can be represented in different domains. In EIS, we use two of these domains, the time domain, and the frequency domain.

In the time domain, signals are represented as signal amplitude versus time. Figure 7 demonstrates this for a signal consisting of two superimposed sine waves.

**Figure 7. Two Sine Waves in the Time Domain**

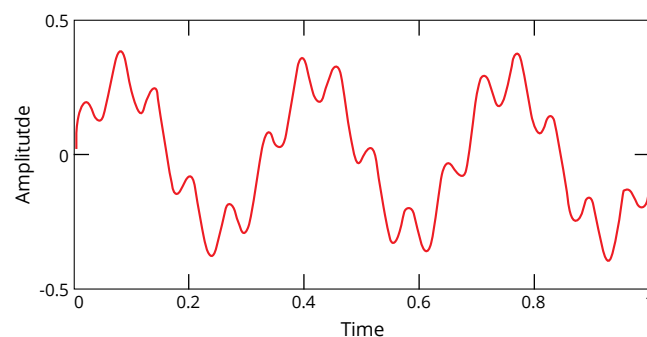
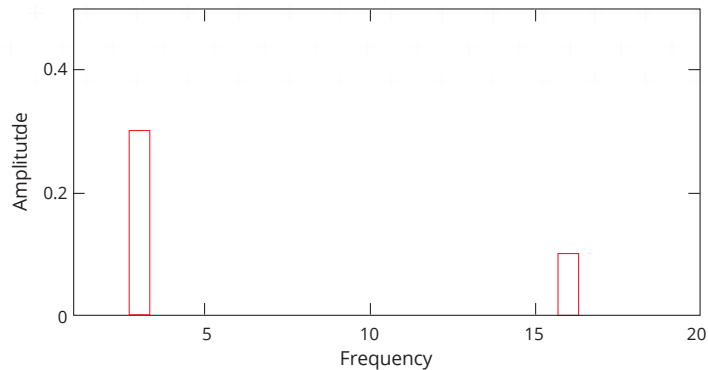

Figure 8 shows the same data in the frequency domain. The data is plotted as amplitude versus frequency.

Figure 8. Two Sine Waves in the Frequency Domain



You use a transform to switch between the domains. The Fourier Transform takes time domain data and generates the equivalent frequency domain data. The common term, FFT, refers to a fast, computerized implementation of the Fourier transform. The inverse Fourier transform changes frequency domain data into time domain data.

In modern EIS systems, lower frequency data are usually measured in the time domain. The controlling computer applies a digital approximation of a sine wave to the cell by means of a digital-to-analog converter. The current response is measured using an analog-to-digital converter. The FFT is used to convert the current signal into the frequency domain.

Details of these transforms are beyond the scope of this Application Note.F





## Electrical Circuit Elements

EIS data are commonly analyzed by fitting to an equivalent electrical circuit model. Most of the circuit elements in the model are common electrical elements such as resistors, capacitors, and inductors. To be useful, the elements in the model should have a basis in the physical electrochemistry of the system. As an example, most models contain a resistor that models the cell's solution resistance.

Some knowledge of the impedance of the standard circuit components is therefore quite useful. Table 1 lists the common circuit elements, the equation for their current versus voltage relationship, and their impedance.

**Table 1. Common Electrical Elements**

Component	Current Vs.Voltage	Impedance
resistor	$E = IR$	$Z = R$
inductor	$E = L di/dt$	$Z = j\omega L$
capacitor	$I = C dE/dt$	$Z = 1/j\omega C$

Notice that the impedance of a resistor is independent of frequency and has no imaginary component. With only a real impedance component, the current through a resistor stays in phase with the voltage across the resistor.

The impedance of an inductor increases as frequency increases. Inductors have only an imaginary impedance component. As a result, the current through an inductor is phase-shifted -90 degrees with respect to the voltage.

The impedance versus frequency behavior of a capacitor is opposite to that of an inductor. A capacitor's impedance decreases as the frequency is raised. Capacitors also have only an imaginary impedance component. The current through a capacitor is phase shifted 90 degrees with respect to the voltage.

#### Serial and Parallel Combinations of Circuit Elements

Very few electrochemical cells can be modeled using a single equivalent circuit element. Instead, EIS models usually consist of a number of elements in a network. Both serial (Figure 9) and parallel (Figure 10) combinations of elements occur.

Fortunately, there are simple formulas that describe the impedance of circuit elements in both parallel and series combination.

Figure 9. Impedances in Series

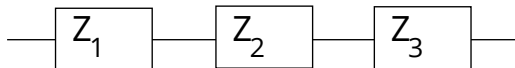

***For linear impedance elements in series you calculate the equivalent impedance from:***

10  $Z_{eq} = Z_1 + Z_2 + Z_3$

Figure 10. Impedances in Parallel

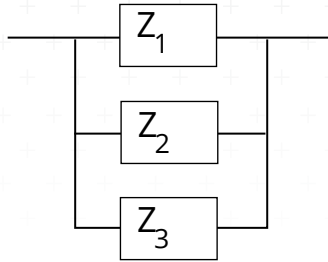

For linear impedance elements in parallel you calculate the equivalent impedance from:

$$11 \quad \frac{1}{Z_{eq}} = \frac{1}{Z_1} + \frac{1}{Z_2} + \frac{1}{Z_3}$$

We will calculate two examples to illustrate a point about combining circuit elements. Suppose we have a 1  $\Omega$  and a 4  $\Omega$  resistor in series. The impedance of a resistor is the same as its resistance (see Table 1). We thus calculate the total impedance as:

$$12 \quad Z_{eq} = Z_1 + Z_2 = R_1 + R_2 = 1 \Omega + 4\Omega = 5 \Omega$$

Resistance and impedance both go up when resistors are combined in series.

Now suppose that we connect two 2  $\mu\text{F}$  capacitors in series. The total capacitance of the combined capacitors is 1  $\mu\text{F}$ .

$$13 \quad \begin{aligned} Z_{eq} &= Z_1 + Z_2 = 1/j\omega C_1 + 1/j\omega C_2 \\ &= 1/j\omega(2e-6) + 1/j\omega(2e-6) \\ &= 1/j\omega(1e-6) \end{aligned}$$

Impedance goes up, but capacitance goes down when capacitors are connected in series. This is a consequence of the inverse relationship between capacitance and impedance.

In the next article in this series we will investigate physical electrochemistry and circuit elements.



## Additional Resources

---

If you need additional information, please visit our website for our online resources and support.



### Technical Support

A compilation of technical support information by hardware and software.



### Software Updates

Licensed users can download the latest version of the Gamry Software.



### Documentation Downloads

Download manuals for hardware and software products.



### Electrochemistry Courses and Training

Information on short courses and electrochemistry training.



### Contact Technical Support

Get support from the electrochemical experts at Gamry.



### Support & Tutorial Videos

For all of our tutorial and support-related videos you can also visit Gamry Instruments YouTube



### Application Notes

A series of Application and Technical Notes to assist you in getting the most accurate results.



### Literature Database

A database of articles where people have used a Gamry System in their research



For help from our technical staff or questions  
about our products, please call us at **215-682-9330**.  
**Gamry.com**



C3 PROZESS- UND  
ANALYSENTECHNIK GmbH  
Peter-Henlein-Str. 20  
D-85540 Haar b. München  
Telefon 089/45 60 06 70  
Telefax 089/45 60 06 80  
info@c3-analysentechnik.de  
www.c3-analysentechnik.de

gamry.com **GAMRY**  
INSTRUMENTS